

LAUDA CALIBRATION THERMOSTATS

Specific application examples

- Calibration of thermometers
- Validation of temperature sensors
- Quality testing heat meter



LAUDA ECO

Calibration and adjustment of temperatures from -25 to 200 °C with LAUDA calibration thermostats

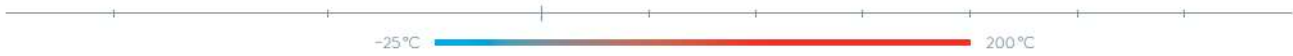

High-performance comprehensive solution for calibration and adjustment

LAUDA calibration thermostats provide constant temperature and homogeneity in calibration and adjustment in the test chamber. Depending on the desired size, bath opening and usable depth, different types are available to choose from – each having variable testing chambers, as well as a comprehensive range of products and accessories. The ability of the thermostat to transfer heat through its heat transfer liquid 40 to 60 times better than through air makes it the perfect solution, especially in comparison to heating cabinets and metal block thermostats.

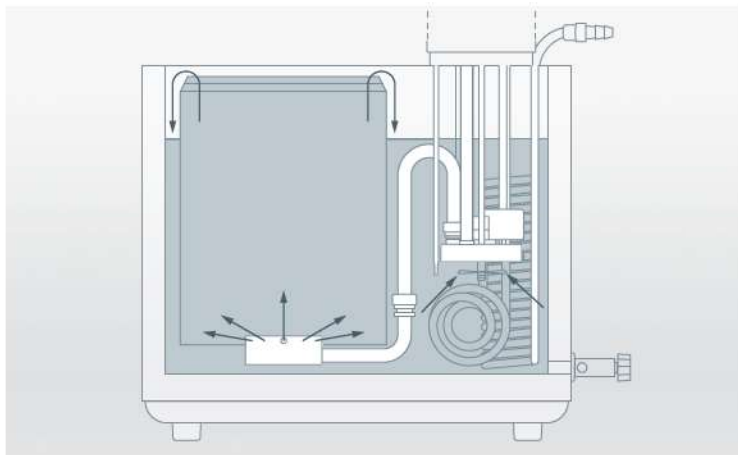

Constant immersion depth thanks to a calibration chamber with overflow principle



Simple operation via TFT display

COOLING PERFORMANCE Heat transfer liquid: Ethanol, bath closed

Bath temperature °C

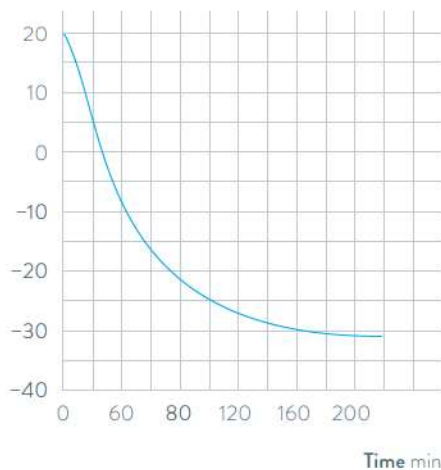

REJ1225 G

Important functions

- LAUDA Vario pump with six selectable output levels
- Vertical adjustment of the temperature chamber possible
- Stainless steel bath vessel (insulated, with handles and drain tap)
- USB interface as standard
- Programmer

Included accessories

Nipples, screw caps, bath cover

Further accessories

Calibration racks

All technical data and power supply variants can be found in the »Technical data« section.

More at www.lauda.de/1772



LAUDA ECO

Temperature stabilities up to $\pm 0.02\text{K}$ at temperatures up to -25°C are achieved with the LAUDA ECO calibration thermostats.

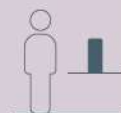

LAUDA Proline

Calibration and adjustment of temperatures from -40°C to 300°C with LAUDA calibration thermostats



High-performance comprehensive solution for calibration and adjustment

LAUDA calibration thermostats provide constant temperature and homogeneity in calibration and adjustment in the test chamber. Depending on the desired size, bath opening and usable depth, different types are available to choose from – each having variable testing chambers, as well as a comprehensive range of products and accessories.

* On request

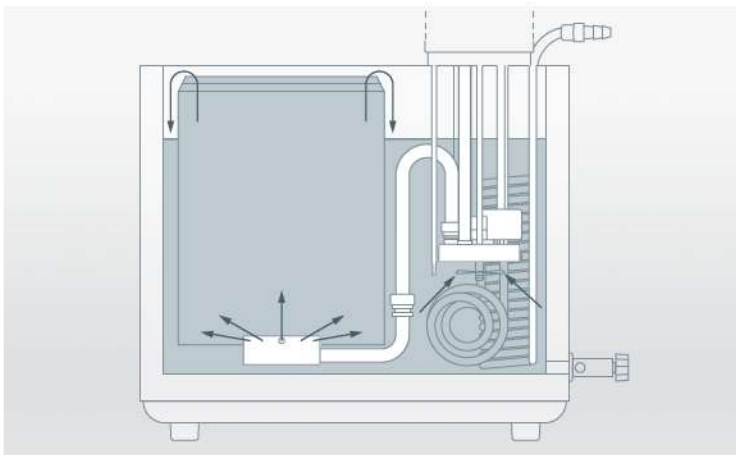

Constant immersion depth thanks to a calibration chamber with overflow principle



Removable remote control ›Command‹ for easy and intuitive operation

HEATING PERFORMANCE Heat transfer liquid: Ultra 240, bath closed

Bath temperature $^{\circ}\text{C}$

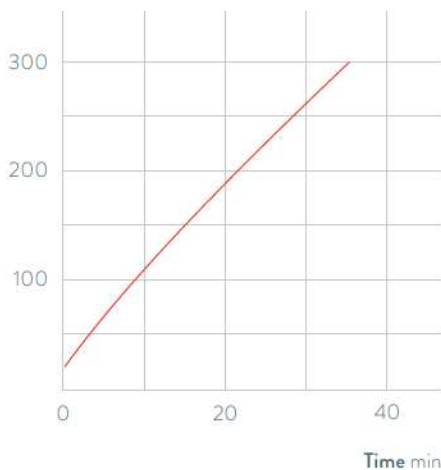

PJ 12/PJ 12 C
(up to 300°C)
PJL 12/PJL 12 C
(up to 200°C)

Important functions

- Stainless steel bath vessel (insulated, with handles and drain tap)
- Selectable Master control head with LED display or detachable Command operating unit with graphic LCD display
- LAUDA Vario Flex pump (pressure pump) with eight selectable output levels
- PowerAdapt system for optimally adapted max. heating output without influencing the mains power supply

Included accessories

Nipples, screw caps, bath cover

Further accessories

Calibration racks

All technical data and power supply variants can be found in the ›Technical data‹ section.

More at www.lauda.de/1774



LAUDA Proline

For maximum temperatures up to 300 °C, the compact models of the LAUDA Proline PJ12 and PJ12 C can be used.

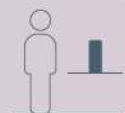

LAUDA Calibration thermostats

Device type overview

LAUDA ECO / Page 132

LAUDA Proline / Page 134



REJ 1225 G

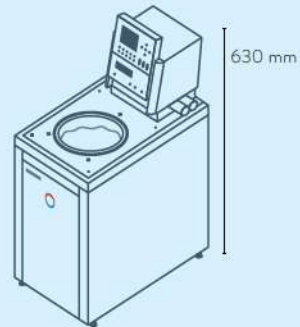

PJ 12 C
PJL 12 C

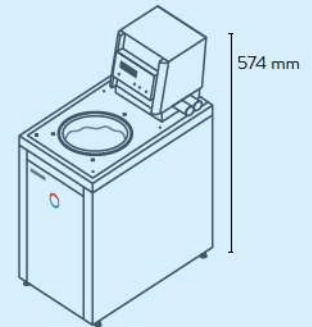

PJ 12
PJL 12

LAUDA Calibration thermostats

Interfaces

	Pt 100 (1)	Pt 100 (2)	USB	Ethernet	RS 232 / 485	Analog	Namur contact	D-Sub contact	PROFIBUS	EtherCAT M8	EtherCAT RJ 45	Malfuction contact	Number of module slots, large	Number of module slots, small
LAUDA ECO REJ 1225 G / Page 132	Z	-	S	Z	Z	Z	Z	-	Z	Z	Z	Z	1	1
LAUDA Proline Master / Page 134	S	-	-	Z	Z	Z	Z	Z	Z	Z	Z	-	2	-
LAUDA Proline Command / Page 134	S	-	-	Z	S	Z	Z	Z	Z	Z	Z	-	2	-

S = Series standard

Z = Available as an accessory



LRZ 912
Analog module



LRZ 913
RS 232/485
interface



LRZ 914
Contact module with single input
and single output (NAMUR)



LRZ 915
Contact module with
3 inputs and 3 outputs



LRZ 917
Profibus module



LRZ 918
Pt100/Li bus module,
small cover



LRZ 921
Ethernet module



LRZ 922
EtherCAT module
with M8 connection

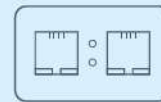

LRZ 923
EtherCAT module
with RJ45 connection



LRZ 925
External Pt100/LiBus-
module, large cover

LAUDA Calibration thermostats

Technical data according to DIN 12876 standard

Device type	Working temperature range °C	Operating temperature range °C	Temperature stability ±K	Safety fittings	Heater power max. kW	Cooling output kW					Pump type	Pump pressure max. bar	Pump flow max. pressure L./min	Pump connection thread mm
						20 °C	10 °C	0 °C	-10 °C	-20 °C				
LAUDA ECO / Page 132														
REJ 1225 G	-25 ... 200	-25 ... 200	0.02	III, FL	2.6	0.30 ¹	-	0.24 ¹	-	0.09 ¹	V	0.6	22.0	M16 × 1
LAUDA Proline / Page 134														
PJ 12	30 ... 300	0 ... 300	0.01	III, FL	3.6	-	-	-	-	-	V	0.8	25.0	M16 × 1
PJ 12 C	30 ... 300	0 ... 300	0.01	III, FL	3.6	-	-	-	-	-	V	0.8	25.0	M16 × 1
PJL 12	30 ... 200	-40* ... 200	0.01	III, FL	3.6	-	-	-	-	-	V	0.8	25.0	M16 × 1
PJL 12 C	30 ... 200	-40* ... 200	0.01	III, FL	3.6	-	-	-	-	-	V	0.8	25.0	M16 × 1

* On request

LAUDA Calibration thermostats

Power supply variants

Device type	Power supply V; Hz	Heater power max. kW	Loading max. kW	Plug code*	Part Number	Device type	Power supply V; Hz	Heater power max. kW	Loading max. kW	Plug code*	Part Number
LAUDA ECO / Page 132											
REJ 1225 G	100 V; 50/60 Hz	1.0	1.3	14	L002851	REJ 1225 G	220 V; 60 Hz	2.4	2.7	3	L002852
REJ 1225 G	115 V; 60 Hz	1.3	1.4	14	L002849						
LAUDA Proline / Page 134											
PJ 12	100 V; 50/60 Hz	1.3	1.5	4	L001947	PJL 12	100 V; 50/60 Hz	1.3	1.5	4	L001949
PJ 12	115 V; 60 Hz	1.7	1.9	4	L001937	PJL 12	115 V; 60 Hz	1.7	1.9	4	L001939
PJ 12	200 V; 50/60 Hz	2.7	2.9	3	L001951	PJL 12	200 V; 50/60 Hz	2.7	2.9	3	L001953
PJ 12	208-220 V; 60 Hz	3.3	3.5	3	L001943	PJL 12	208-220 V; 60 Hz	3.3	3.5	3	L001945
PJ 12 C	100 V; 50/60 Hz	1.3	1.5	4	L001948	PJL 12 C	100 V; 50/60 Hz	1.3	1.5	4	L001950
PJ 12 C	115 V; 60 Hz	1.7	1.9	4	L001938	PJL 12 C	115 V; 60 Hz	1.7	1.9	4	L001940
PJ 12 C	200 V; 50/60 Hz	2.7	2.9	3	L001952	PJL 12 C	200 V; 50/60 Hz	2.7	2.9	3	L001954
PJ 12 C	208-220 V; 60 Hz	3.3	3.5	3	L001944	PJL 12 C	208-220 V; 60 Hz	3.3	3.5	3	L001946

¹Pump output step 3

Nipples \varnothing_e	Bath volume min. L	Bath volume max. L	Bath opening \varnothing mm	Bath depth mm	Usable depth mm	Height top of bath mm	Dimensions (W x D x H) mm	Weight kg	Power supply V; Hz	Loading max. kW	Part Number	Device type
13	9.3	12.0	150	200	180	443	250×435×624	30.4	230 V; 50 Hz	2.9	L002848	REJ 1225 G
13	8.5	13.5	120	320	300	374	220×360×574	17.0	230 V; 50/60 Hz	3.7	L001923	PJ 12
13	8.5	13.5	120	320	300	374	220×360×630	17.0	230 V; 50/60 Hz	3.7	L001924	PJ 12 C
13	8.5	13.5	120	320	300	374	220×360×574	17.0	230 V; 50/60 Hz	3.7	L001925	PJL 12
13	8.5	13.5	120	320	300	374	220×360×630	17.0	230 V; 50/60 Hz	3.7	L001926	PJL 12 C